

6-1-2018

Design and development of a linear jawed gripper for unstructured environments

Y Shrihari Upadhyaya

Manipal Institute of Technology, MAHE, Manipal, India, ys.upadhyaya@manipal.edu

Follow this and additional works at: <https://impressions.manipal.edu/mjst>



Part of the [Engineering Commons](#)

Recommended Citation

Upadhyaya, Y Shrihari (2018) "Design and development of a linear jawed gripper for unstructured environments," *Manipal Journal of Science and Technology*. Vol. 3: Iss. 1, Article 3.

Available at: <https://impressions.manipal.edu/mjst/vol3/iss1/3>

This Original Research Article is brought to you for free and open access by the MAHE Journals at Impressions@MAHE. It has been accepted for inclusion in Manipal Journal of Science and Technology by an authorized editor of Impressions@MAHE. For more information, please contact impressions@manipal.edu.

Design and development of a linear jawed gripper for unstructured environments

Dhruv Kool Rajamani, Kulpreet Singh Dhankar, Eswar Deep Pitchika, Y Shrihari Upadhyaya*

Email: ys.upadhyaya@manipal.edu

Abstract

Today's manufacturers aim to reduce costs, increase agility, and automate processes - including high-mix, labour intensive ones. Grippers are used to automate most processes and are thus required to be precise, have fast cycle times, and have the capacity to lift heavy loads.

This paper discusses the ways to improve automated processes by implementing linear jawed grippers as a replacement for the current parallelogram grippers. Using various tools for CAD, analysis and simulation, an optimized linear jawed gripper has been designed. In order to provide precision and speed, an innovative feedback system has also been discussed using a combination of tactile sensors and current sense feedback techniques. The technical overview of the gripper is clubbed under three broad topics – Design and Analysis, Control and Electronic Design, Comparative Analysis.

Keywords: Current sense, industrial gripper, linear gripper, motor driver, tactile sensing, underactuation

I. Introduction

The end effector is a component providing the desired manipulation at the end of a robotic arm. It acts as the last link in any serial or parallel manipulator and is responsible for all operations the robot performs on a workpiece. The generic grippers are of three types – linear, level, and parallelogram (Figure 1). The grippers designed for industries are required to manipulate heavy payloads in short and fast cycles. Such grippers use a variety of actuation methods – pneumatic actuators, worm and worm wheel, hydraulic actuators, etc.

The mechanically self-adaptive mechanism paves the way for the lightweight design of grippers which

perform reliable gripping for a wide range of objects without the need for complex control [1]. In this paper, we propose a model linear gripper which employs a set of underactuated jaws as a replacement for the current grippers used in the industry.

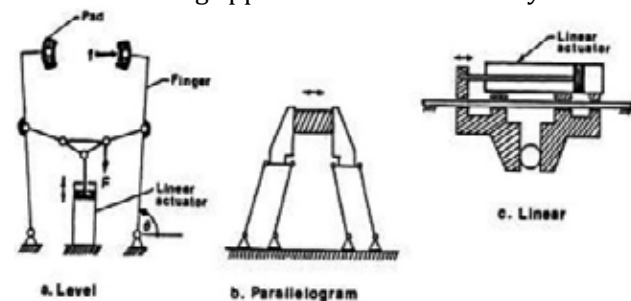

Figure 1: Types of grippers

Dhruv Kool Rajamani

BTech Second Year Student, Dept of Mechatronics Engg, Manipal Institute of Technology, MAHE, KA - 576104

Kulpreet Singh Dhankar

BTech Second Year Student, Dept of Mech and Mfg Engg, Manipal Institute of Technology, MAHE, KA - 576104

Eswar Deep Pitchika

BTech Second Year Student, Dept of Electronic and Comm Engg, Manipal Institute of Technology, MAHE, KA - 576104

Y Shrihari Upadhyaya

Associate Professor-Senior Scale, Dept of Mech and Mfg Engg, Manipal Institute of Technology, MAHE, KA - 576104

* Corresponding Author

A. Linear gripper

The complexity of the grasping process is often underestimated since it looks very familiar for human beings [2]. The design of an industrial gripper must ensure proper handling of objects as well as offer maximum grip, precision, repeatability, etc. Further, the gripping action needs to be quick and the links should be able to apply a horizontal force equal to the weight of the workpiece times the frictional coefficient of the pad (μ). The workpieces vary in both size and weight, causing complexities in the gripper

How to cite this article: Dhruv Kool Rajamani, Kulpreet Singh Dhankar, Eswar Deep Pitchika, Y Shrihari Upadhyaya, "Design and development of a linear jawed gripper for unstructured environments", Manipal J. Sci. Tech., vol.3(1),14-19, 2018.

design due to less contact, inadequate work volumes and high reverse torques which inadvertently lead to gripper failure. Due to the excessive application of force, the workpiece can deform, wear, etc. thus, devaluing the product.

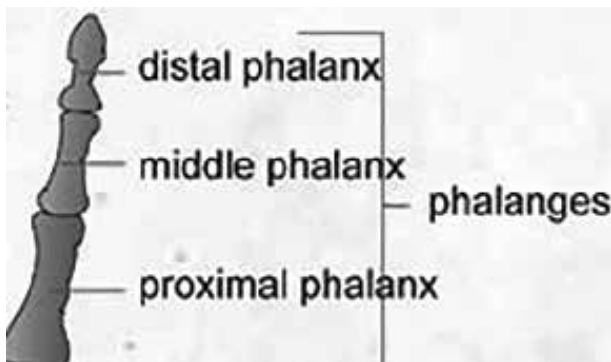

Figure 2: Human finger physiology [7]

A linear gripper provides a uniform horizontal gripping force allowing an evenly distributed force on the workpiece. The mechanism also allows a larger work volume since there is not any mechanical restriction between the jaws.

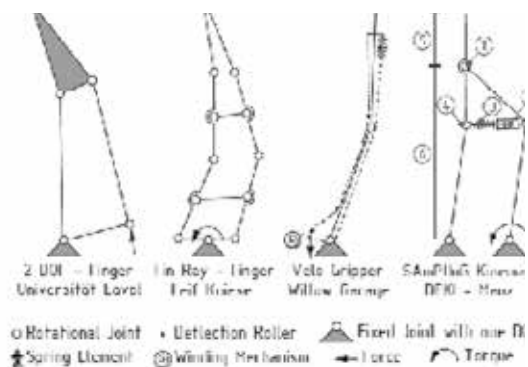

Figure 3a

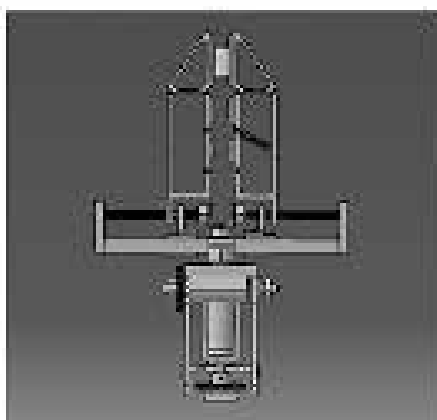

Figure 3a

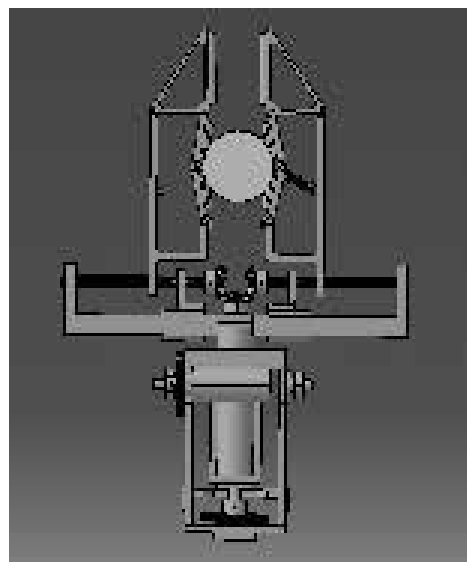

Figure 3c

Figure 3: (a) Types of underactuated mechanisms [1] (b) Precision grasp using distal phalanx (c) Power grasp using middle and proximal phalanx

B. Analogous to human physiology

It is common knowledge that the human hand is the pinnacle of a gripper design. The mechanical designs of a multitude of grippers try to mimic the human hand, as seen in [4], [5]. Humans vary the force used for grasping depending on the arising external forces and parameters like the friction between object and skin [1]. Our design approach is directed at achieving a stable grasp and not in-hand manipulation. In order to achieve the maximum envelope of the workpiece, we believe two types of grasps are critical. The first being parallel grasp which is applicable for smaller objects around which the fingers are unable to close completely. The distal phalanx plays a crucial role in performing such grasps by exerting a normal force to lift and manipulate the object. The second type of grasp completely envelopes the circumference of the workpiece as and when the diameter of the workpiece is larger than the lengths of the distal phalanx, all the phalanges undergo flexion to achieve this grasp. These grasps are well suited for resisting a wide range of external disturbances, unlike parallel grasps, which are easily affected by the torques applied around the axis of contact [3]. As shown in Figure 3(b) the gripper jaws have self-adjusted themselves to envelope the workpiece and in Figure 3(c) the gripper jaws remain parallel since the object is very small.

II. Mechanical design

The design process started with a basic dimensional synthesis using CATIA V6. A definitive work volume was decided, and a 3D model was conceived. The design was then iteratively simulated and redesigned changes were made to the mechanisms, kinematic arrangements, methods of power transmission, and dimensioning of the links. After the final model was conceived, an appropriate control system using an STM32, custom motor drivers and strain gauges for feedback was simulated. After multiple iterations involving changes to the code, appropriate joystick mapping, interfacing and wiring, the gripper was 3D printed using rapid prototyping and the entire system was tested.

A. Dynamic analysis

As mentioned before, in order to achieve an optimum grasp, the gripper jaws were modelled on the human finger. Depending on the type of grasp, the forces exerted by each phalange were calculated and re-evaluated during simulation and analysis. A standardized mean along with a respectable factor of safety was then estimated and the required grip force was finalized. This method of analysis allowed us to obtain an optimum design for the power transmission mechanisms, helping us achieve an optimized weight to performance ratio.

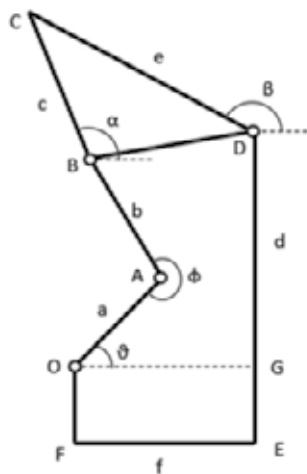

Figure 5: Line diagram of gripper jaw

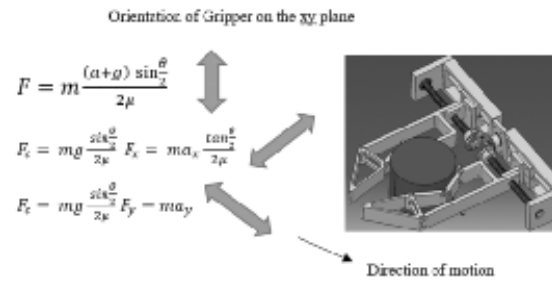

Figure 5a

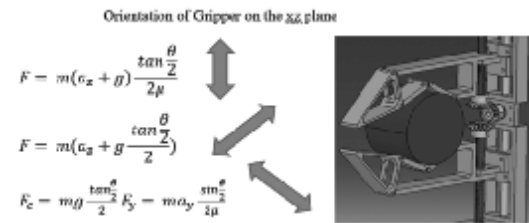

Figure 5b



Figure 5c

Figure 5: Force equations for gripper orientation along: (a) xy plane, (b) xz plane, (c) yz plane

B. Positional analysis

We mathematically modelled our gripper links to theoretically predict the grasping action. Using this model, we were able to describe the position of the phalanges with varying workpiece diameters.

$$\begin{aligned}
 X &= a \cos \theta + b \cos (\varphi - \theta) + c \cos \alpha \\
 Y &= a \sin \theta + b \sin (\varphi - \theta) + c \sin \alpha \\
 X &= f + e \cos \beta \\
 Y &= d + e \sin \beta
 \end{aligned}$$

Figure 6a

$$\begin{aligned}
 \tan^2 \left(\frac{\theta}{2} \right) & \{ 2ab \cos (2\theta - \varphi) - 2f [a \cos \theta + b \cos (\varphi - \theta)] - 2d [a \sin \theta + b \sin (\varphi - \theta)] - \\
 & 2ac \cos \theta - 2bc \cos (\varphi - \theta) + 2fc - k \} + 2 \tan \left(\frac{\theta}{2} \right) [2ac \sin (\theta) + 2bc \sin (\varphi - \theta) - 2d] + \\
 & [2ab \cos (2\theta - \varphi) - 2f [a \cos \theta + b \cos (\varphi - \theta)] - 2d [a \sin \theta + b \sin (\varphi - \theta)] + 2ac \cos \theta + \\
 & 2bc \cos (\varphi - \theta) - 2fc - k] = 0
 \end{aligned}$$

Where $k = e^2 - a^2 - b^2 - c^2 - d^2 - f^2$

Figure 6b

$$\begin{aligned}
 \tan^2 \left(\frac{\beta}{2} \right) & \{ 2ah \cos (2\theta - \varphi) - 2f [a \cos \theta + b \cos (\varphi - \theta)] - 2d [a \sin \theta + b \sin (\varphi - \theta)] - \\
 & 2ae \cos \theta + 2be \cos (\varphi - \theta) + 2f e - k \} \\
 & + 2 \tan \left(\frac{\beta}{2} \right) [2de - 2ae \sin \theta - 2be \sin (\varphi - \theta)] \\
 & + [2ah \cos (2\theta - \varphi) - 2f [a \cos \theta + b \cos (\varphi - \theta)] - 2d [a \sin \theta + b \sin (\varphi - \theta)] \\
 & + 2ae \cos \theta + 2be \cos (\varphi - \theta) + 2f e - k] = 0
 \end{aligned}$$

Where $j = c^2 - a^2 - b^2 - e^2 - d^2 - f^2$

Figure 6c

C. Power transmission

In this design, a power screw mechanism was used to lift the object. The estimated normal force to pick and hold a 5-kg object is 150 N which includes factor of safety. The torque τ required to lift the object is given by the formula;

$$\tau = 0.5 * d_m * W * \frac{[\mu + \cos\theta n * \tan\alpha]}{[\cos\theta n - \mu * \tan\alpha]} - d_{mc} * \mu_c * W * 0.5$$

where various notations were used, and the related equations have been given as under:

- μ - Coefficient of friction between screw and nut
- α - Lead angle
- d_m - Mean screw diameter (Meter)
- W- Force required to lift the object
- D_{mc} - Mean collar radius
- μ_c - Thrust collar friction value
- p - Pitch of the screw
- n - Number of starts

$$\alpha = \arctan \left(n * \frac{p}{\pi * d_m} \right)$$

$$\theta n = \arctan(\cos\alpha * \tan\theta)$$

$$p = \text{thread depth} / 0.614$$

$$\text{velocity ratio} = \cot\alpha = \frac{\pi * d_m}{n * p}$$

$$\text{Efficiency} = \frac{d_m * \tan\alpha}{d_m * \frac{[\mu + \cos\theta n * \tan\alpha]}{[\cos\theta n - \mu * \tan\alpha]} - d_{mc} * \mu_c}$$

Using the above formulae, the **required torque** came out to be **8.3 kg cm** with M8 bolt (ISO 724:1993).

The following DC geared motor was employed:

Table 1: Motor specifications

No-Load Speed	Min. Stall Torque	Net Weight	Rated Voltage
170 RPM	22.04 kg-cm	90 g	12V DC

Using the velocity ratio formula mentioned above, the power screw operates at a speed of 15.25 mm/sec.

III. Controller design

Every Mechatronic system requires a well-tailored control system to augment its mechanical components. Ever since the development of the first

programmable robotic arm - Unimate, controller design for robotic systems is a booming industry. A control system consists of a control component such as a microcontroller, programmable logic controller or even a 555 timer which generates control signals for motors. Since high torque motors run at voltages higher than 5V, motor drivers help interface between the controller and the motor. A system of sensors and amplifiers is also employed to provide feedback to the controller allowing the robotic system to achieve high repeatability and reduce errors

A. Microcontroller selection

By definition, a microcontroller is a computer on an integrated circuit, comprising of a processor, memory, and programmable I/O peripherals. Microcontrollers are selected on the basis of numerous factors such as modes of operation, speed, architecture, memory, etc. For our gripper, we selected a 32-bit ARM based STM32 microcontroller due to its low power consumption, high baud rate, large number of I/O pins, and its inbuilt clock. The STM32 allows precise control of the gripper without compromising on speed.

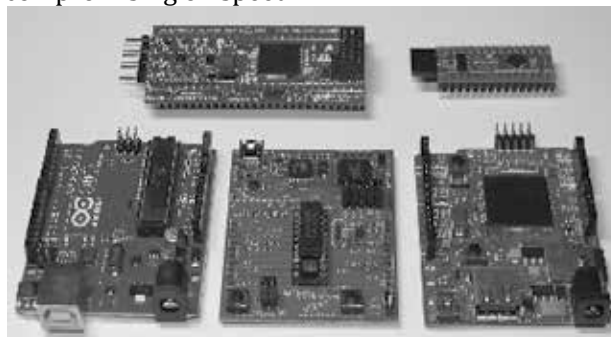

Figure 7 - a

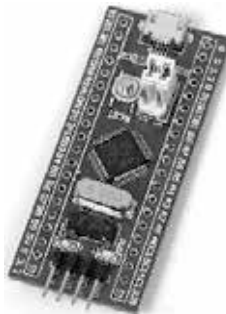

Figure 7 - b



Figure 7 - c

B. Motors and motor drivers

The motors and actuators are one of the most vital components of any mechatronic system. They can

be classified as DC and AC motors, depending on their source of power. This gripper uses a single brushed DC geared motor due to its low cost, availability, and ease of use. The motor was selected on the basis of the required torque, rpm, and voltage requirements.

To complement the PMDC motor used, we used the 12V motor drivers based on the principle of the H-Bridge (Figure 3). A motor driver is an interface between a microcontroller and a motor. It is highly efficient and provides precise control while supplying an optimum voltage to the motor. Due to the high cost and scarcity of reliable motor drivers, we designed our own custom motor drivers. These drivers use a single MOSFET as a switching element and relays to channelize the current to the motors.

IV. Encoding, Feedback and DAQ

The gripper employs a set of strain gauges and a novel approach to sense current drawn by the motor. The strain gauges provide tactile feedback and a measure of force applied on each gripping pad. Each strain gauge is placed beneath a visco-elastic silicon layer, allowing it to measure strain whenever the pads deform upon gripping. The current sense also provides an indication of when the object is gripped. As the pads grip an object, the motor draws more current than its reference current indicating that the object is gripped.

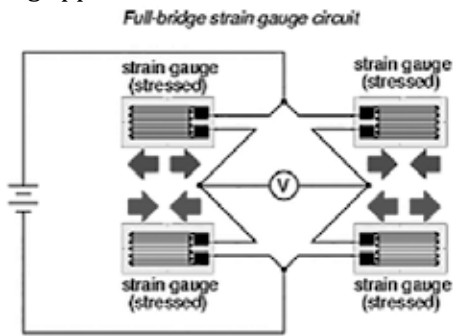

Figure 8a

ρ = Resistivity
 ϵ = Strain
 Gf = Gauge Factor
 η = Poisson's Ratio

$$\frac{\Delta R/R}{\epsilon} = 2\eta + 1 + \frac{1}{\epsilon} \left(\frac{\Delta \rho}{\rho} \right)$$

$$Gf = \frac{\Delta R/R}{\epsilon}$$

$$\frac{V_o}{V_E} = -Gf * \epsilon$$

Figure 8b

Figure 8: (a) Full bridge strain gauge circuit for minimum error (b) Equations to calculate strain for change in Voltage

A. Force feedback

Strain gauges are transducers that convert pressure, tension, etc., into a change in electrical resistance. Since the change in current is very small, a simple INA125P helps amplify the signal to make it into a readable value. The measured value of the current can then be equated to an applied strain which when coupled with the elasticity of the silicon pad provides a value of the force. The equations to help convert the change in resistance to a measurable value of force can be seen in Figure 8.

B. Current sense

Current sense is a method of sensing the current drawn by the motor, by measuring the voltage drop across a low-valued sense resistor. Three options are available for current sensing: low side, high side, and on the motor. Accordingly, you can place the sense resistor between the H-bridge and ground (low-side current sensing) (Figure 9 (b)), on the bottom of the DC bus or between the positive battery terminal and H-bridge (high-side current sensing), or on the high-side of the DC bus or the motor itself (output motor PWM current sensing) [6].

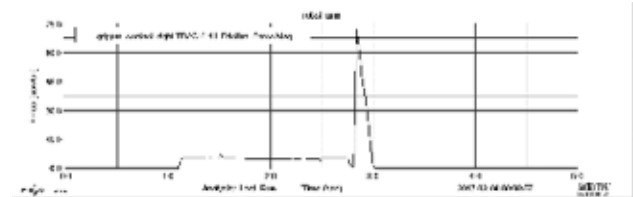

Figure 9: Contact Force vs Time

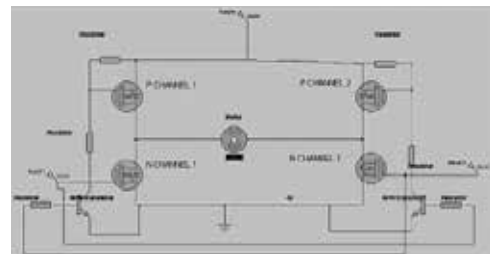

Figure 9a

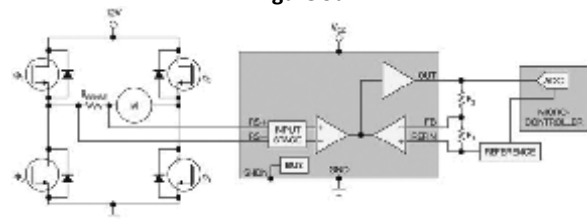

Figure 9: You can construct a PWM-compatible, H-bridge current-sensing circuit.

Figure 9: (a) Custom Motor Driver Circuit (b) Modified Motor Driver Circuit with Instrumentational Amplifier, modified to accommodate sense resistor [6]

V. Conclusion and future work

The goal of this project was to design a linear gripper to replace the grippers that are currently being used in the automated industries. The proposed model of a linear gripper was designed, simulated, manufactured, and tested. An appropriate control system was implemented with added features such as current sense and tactile sensing.

For designing the gripper, appropriate positional, kinematic and dynamic models were created to help optimize the generic design of a linear gripper. In order to achieve a stable grasp, the gripper jaws are non-holonomically constrained linkages that allow two types of grasps, suited to all types of objects – precision grasping and power grasping.

In the future, we plan to implement a closed loop feedback using the tactile sensors and current sense to provide precise grasps that dynamically change with changes in acceleration. This will reduce the time it takes to grasp and reduce the power input, thus increasing the overall efficiency of the gripper. Along with an optimized control system, we also plan on experimenting with a torsion spring in place of the compression spring used in the jaw to provide a more precise grasp.

References

- [1] M. Manz, S. Bartsch, M. Simnofske and F. Kirchner, "Development of a Self-Adaptive Gripper and Implementation of a Gripping Reflex to Increase the Dynamic Payload Capacity," *Proceedings of ISR 2016: 47th International Symposium on Robotics*, Munich, Germany, 2016, pp. 1-7.
- [2] Gualtiero Fantoni, Marco Santochi, Gino Dini, Kirsten Tracht, Bernd Scholz-Reiter, Juergen Fleischer, Terje Kristoffer Lien, Guenther Seliger, Gunther Reinhart, Joerg Franke, Hans Nørgaard Hansen, Alexander Verl, Grasping devices and methods in automated production processes, *CIRP Annals - Manufacturing Technology*, Volume 63, Issue 2, 2014, Pages 679-701, ISSN 0007-8506, <http://dx.doi.org/10.1016/j.cirp.2014.05.006>.
- [3] Matei Ciocarlie, Fernando MierHicks, Robert Holmberg, Jeffrey Hawke, Michael Schlicht, Jeff Gee, Scott Stanford, Ryan Bahadur, "The Velo gripper: A versatile single-actuator design for enveloping, parallel and fingertip grasps," *The International Journal of Robotics Research*, Vol 33, Issue 5, pp. 753 - 767
- [4] W. Widhiada, T. G. T. Nindhia, and N. Budiarsa, "Robust Control for the Motion Five Fingered Robot Gripper," *International Journal of Mechanical Engineering and Robotics Research*, Vol.4, No. 3, pp. 226-232, July 2015. DOI: 10.18178/ijmerr.4.3.226-232
- [5] Leo Jiang, K. Low, J. Costa, R. J. Black and Y. L. Park, "Fiber optically sensorized multi-fingered robotic hand," *2015 IEEE/RSJ International Conference on Intelligent Robots and Systems (IROS)*, Hamburg, 2015, pp. 1763-1768.
- [6] Gavardoni, Maurizio. "Accurate High-Side Current-Sense Amplifier Monitors PWM Load Current." *Accurate High-Side Current-Sense Amplifier Monitors PWM Load Current - Application Note - Maxim*. N. p., n. d. Web. 25 June 2017.
- [7] Infovisual.info. (2017). *Bones of the hand - Visual Dictionary*. [online] Available at: <https://infovisual.info/en/human-body/bones-of-the-hand> [Accessed 25 Jun. 2017].
- [8] A. Karakerezi, Z. Doulgeri, and V. Petridis, "A gripper for handling flat non-rigid materials," *Automation and Robotics in Construction XI*, pp. 593-601, 1994.
- [9] Q. Wang, Q. Quan, Z. Deng, and X. Hou, "An Underactuated Robotic Arm Based on Differential Gears for Capturing Moving Targets: Analysis and Design," *Journal of Mechanisms and Robotics*, vol. 8, no. 4, p. 041012, 2016.
- [10] B. Gao, S. Yang, H. Jin, Y. Hu, X. Yang, and J. Zhang, "Design and analysis of underactuated robotic gripper with adaptive fingers for objects grasping tasks," *2016 IEEE International Conference on Robotics and Biomimetics (ROBIO)*, 2016.
- [11] A. Wolf, R. Steinmann, and H. Schunk, *Grippers in motion*. Berlin: Springer, 2010.